

A C U



Electric Motor Driven Submersible Pump

Model S8C1 460V 3P and S8C1 575V 3P Size 8"



PUMP SPECIFICATIONS

- Diffuser:** Ductile Iron 80-60-03;
Maximum Operating Pressure 195 psi (1345 kPa).*
- Impeller:** Ductile Iron 80-55-06.
- Suction Head:** Gray Iron 30.
- Motor Housing:** Aluminum Alloy 356-T6.
- Intermediate Bracket:** Aluminum Alloy 356-T6.
- Seal Plate:** Gray Iron 30.
- Motor Shaft:** Stainless Steel 17-4 PH.
- Bearings:** Upper, Open Single Row Ball.
Lower, Sealed Double Row Ball.
- Discharge Flange:** Gray Iron 30.
- Gaskets:** Cork ^{w/}Nitrile Binder (NC710) and Vegetable Fiber.
- O-Ring:** Buna-N
- Wetted Hardware:** Standard Plated Steel and Stainless Steel.
- Strainer:** Urethane Coated Steel; 49% Open Area, 0.62" (15,7 mm)
Square Openings.
- Hoisting Bail.** Urethane Coated Steel.
- Standard Equipment:** NEMA Type 3R Rainproof Control Box.
Provides On-Off, Circuit Breaker and Motor Overload Protection.
(See Section 130, Page 100.)
- Optional Equipment:** Turtle Type Pressure Activated Level Switch. Float
Activated Level Switch. (See Sec. 130, Page 150.)



MOTOR/CABLE SPECIFICATIONS

- Motor:** Oil Filled Enclosure; 140 H.P.; 1750 R.P.M.; Three Phase:
460/575 Volt, 60 Hz, 176/141 Full Load Amps, 112 kW (Max.)
- Power Cable:** 6 Wire; Type GGC; 2/0 AWG (460V); 1 AWG (575V);
3 Power Conductors, 2 Ground Conductors and 1 Ground Check.
Nominal Length 50 Feet (15 m) Standard.
(Specify Alternate Length at Time of Order.)
- Recommended Generator Size:** 200 kW Across-the-Line Start, 150 kW
for Reduced Voltage Starting.

* Consult Factory for Applications Exceeding Maximum Pressure and/or Temperature Indicated.

WARNING!

Do not use in explosive atmosphere or for pumping volatile flammable liquids.

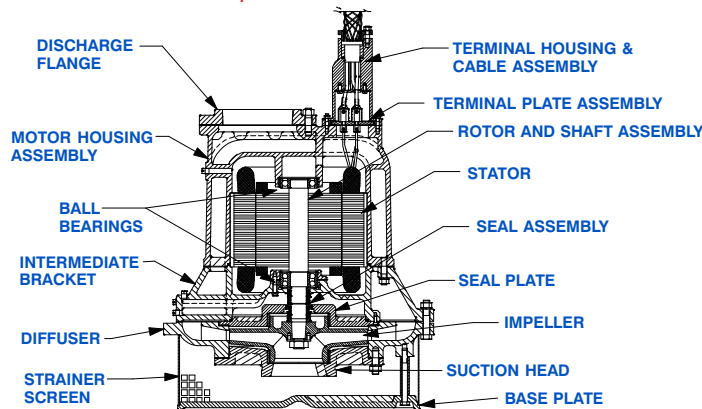
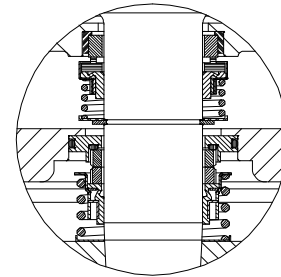

SEAL SPECIFICATIONS

- Tandem, Oil Lubricated.
- Upper Seal:** Type 21, Mechanical. Carbon Rotating Face. Ni-Resist Stationary Face. Buna-N Elastomers. Stainless Steel 18-8 Cage and Spring.
- Lower Seal:** Type 2, Mechanical. Tungsten Titanium Carbide Rotating and Stationary Faces. Stainless Steel 316 Stationary Seat. Fluorocarbon Elastomers (DuPont Viton[®] or Equivalent). Stainless Steel 18-8 Cage and Spring.
Maximum Temperature of Liquid Pumped, 122°F (50°C).*



THE GORMAN-RUPP COMPANY • MANSFIELD, OHIO
GORMAN-RUPP OF CANADA LIMITED • ST. THOMAS, ONTARIO, CANADA

www.grpumps.com
Specifications Subject to Change Without Notice

Printed in U.S.A.

Specification Data

SECTION 130, PAGE 1560

APPROXIMATE
DIMENSIONS and WEIGHTS

NET WEIGHT: 1610 LBS. (730,3 KG.)
SHIPPING WEIGHT: 1664 LBS. (754,8 KG.)
EXPORT CRATE: 38 CU. FT. (1,08 CU. M.)

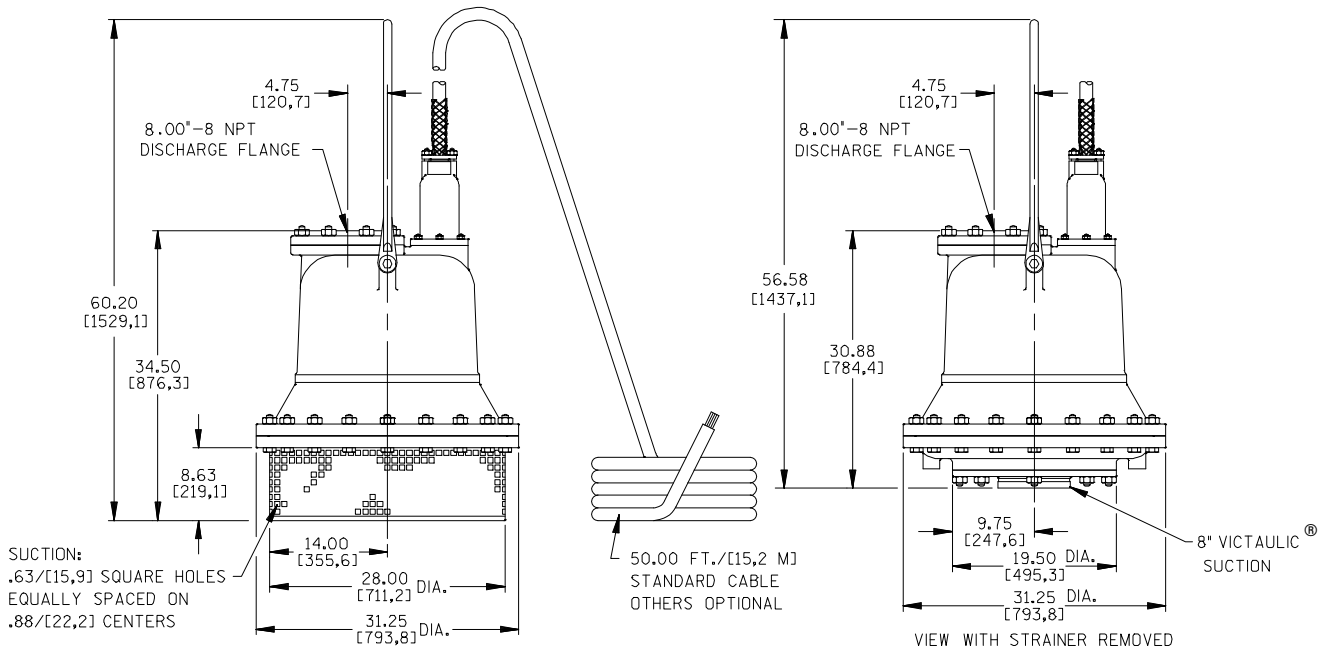

DIMENSIONS:
INCHES
[MILLIMETERS]

Victaulic® is a Registered Trademark of Victaulic Company of America.

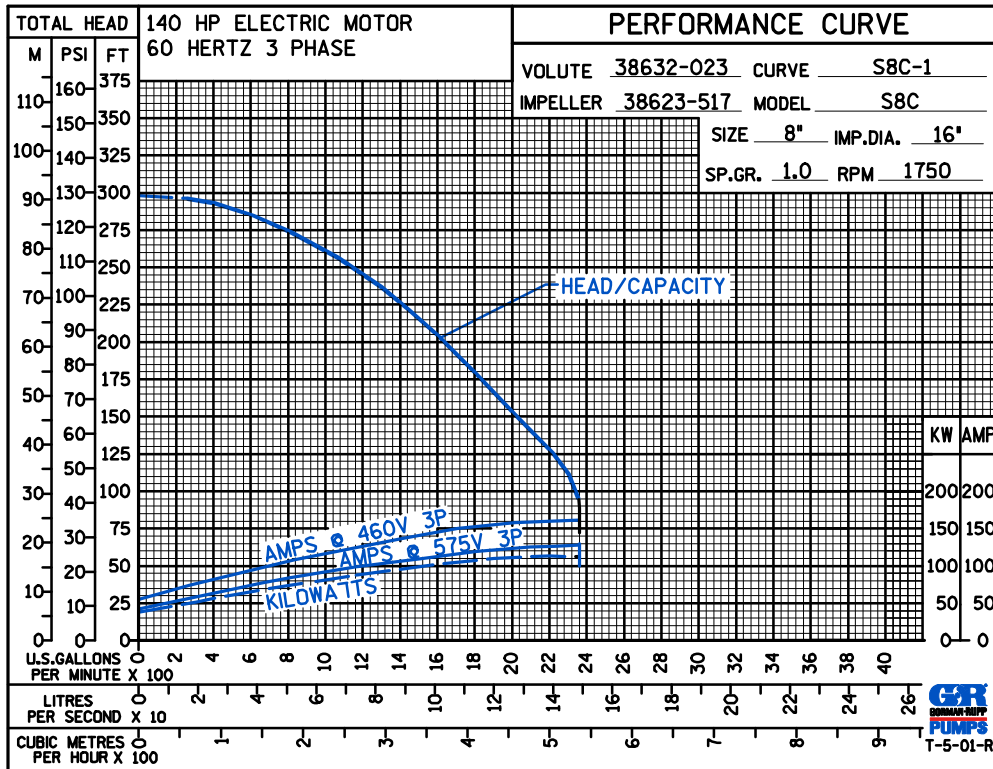

THE GORMAN-RUPP COMPANY • MANSFIELD, OHIO

GORMAN-RUPP OF CANADA LIMITED • ST. THOMAS, ONTARIO, CANADA

Specifications Subject to Change Without Notice

Printed in U.S.A.